

GEHL®

GBL-X-920

KEY FEATURES

- ✓ Fuel-efficient Perkins engine, 92 hp
- ✓ Center mount chassis
- ✓ Smart UC Hydraulics for Low Fuel Consumption
- ✓ Reliable Carraro Axle Transmission
- ✓ Larger Standard Front Wheels
- ✓ Covered, Protected and Well-Routed Hoses
- ✓ Ergonomically Designed Cab



BACKHOE LOADERS

TECHNICAL SPECIFICATIONS

		BL818
ENGINE	Perkins Turbocharged, Water-Cooled, Tier II engine	1104C-44T
	Gross Power @ 2200 rpm - (hp)	68.5 kW (92)
	Capacity	4.4 liter
	Torque @ 1350 rpm	395 nm
HYDRAULICS	Maximum Flow @ 2200 rpm (both pumps)	145 lpm (81+64)
	Main Relief Pressure	3250 psi (225 bar)
	Dual Work Modes: Economy and power by selection of twin vs. single pump	
TRANSMISSION	Carraro transmission, Four Speed (4 forward, 4 reverse gear) Synchro shift reversing shuttle transmission, with modulated clutch packs	✓
	Two Wheel Drive is standard (four wheel drive optional)	✓
	Torque Converter Stall Ratio - 3.01:1	✓
AXLE	Rear Drive Axle rigidly mounted with outboard planetary final drives for easy maintenance	✓
	Front-steer Axle with 16° oscillation for maximum ground contact in undulated conditions	✓
STEERING/ BRAKES	Reliable hydraulically assisted power steering	✓
	Self-actuating and self-adjusting, high capacity, sealed, wet disc brakes, maintenance free	✓
TIRES	Front Standard Traction 12.5 x 18 - 12 PR Optional/Heavy-Duty 9 x 16 - 16 PR	✓
	Rear Standard Traction 16.9 x 28 - 12 PR Optional/Heavy-Duty 14 x 25 - 20 PR	✓
ELECTRICAL	12V and 75A system with water and dust proof connectors and 130 AH low maintenance battery	✓
SPEEDS	Forward/Reverse Gear	1st Gear 5.4 km/hr 2nd Gear 8.6 km/hr 3rd Gear 19.9 km/hr 4th Gear 40 km/hr
	BUCKETS	Loader Bucket Standard Capacity 1.0 cu m Width 2235 mm Backhoe Bucket Standard Capacity 0.24 cu m Width 892 mm Optional Backhoe Buckets 0.08 cu m, 0.09 cu m, 0.12 cu m, 0.18 cu m, 0.27 cu m, 0.31 cu m
STATIC DIMENSIONS	Overall Length	7338 mm
	Overall Height	3762 mm
	Wheelbase	2130 mm
	Overall Width	2330 mm
	Cabin Height	2770 mm
	Ground Clearance	400 mm

BACKHOE PERFORMANCE RANGE & FOCUS		Standard Dipper	Extending Dipper	
			Retracted	Extended
BACKHOE PERFORMANCE RANGE & FOCUS	A. Maximum Dig Depth - (ft)	4741 mm (8'11")	4741 mm (15'6")	5815 (19'1")
	B. Maximum Reach - (ft) Ground Level to Slew Center	5730 mm (18'10")	5730 mm (18'10")	7020 mm (23'1")
	C. Maximum Loading Reach - (ft)	1996 mm (6'7")	1996 mm (6'7")	2924 mm (9'7")
	D. Maximum Operating Height - (ft)	5659 mm (18'7")	5659 mm (18'7")	6637 mm (21'9")
	E. Maximum Loading Height SAE - (ft)	3553 mm (11'8")	3553 mm (11'8")	4531 mm (14'10")
		Maximum Loading Height - (ft)	3871 mm (12'8")	3871 mm (12'8")
	F. Maximum Straight Wall Dig Depth - (ft)	2602 mm (8'5.4")	2602 mm (8'5.4")	3991 mm (13'0")
	G. Maximum Bucket Rotation	194°	194°	194°
	Dipper Tear Out	3946 kgf	3946 kgf	2644 kgf
	Bucket Tear Out	5219 kgf	5219 kgf	5219 kgf
Hydraulic Lift Capacity	1384 kgf	1184 kgf	812 kgf	
LOADER PERFORMANCE		Standard Shovel		7-in-1 Shovel
	N. Maximum Dump Height at 45° - (ft)	2708 mm (8'11")	2708 mm (8'11")	
	O. Maximum Loadover Height - (ft)	3310 mm (10'10")	3319 mm (10'10")	
	P. Maximum Hinge Pin Height - (ft)	3550 mm (11'8")	3550 mm (11'8")	
	S. Maximum Reach at Full Height - (ft)	1282 mm (4'3")	1282 mm (4'3")	
	T. Maximum Reach at Full Height 45° - (ft)	829 mm (2'9")	829 mm (2'9")	
	U. Below Ground Dig Depth - (ft)	156 mm (6")	156 mm (6")	
	Rollback at Ground	45°	45°	
	Maximum Dump Angle	57°	57°	
	V. Maximum Operating Height - (ft)	4230 mm (13'11")	4298 mm (14'1")	
OPERATING WEIGHT	Machine Kerb Weight			6885 kg
	Machine Kerb Weight with 4WD			6985 kg
	Machine Kerb Weight with 4WD & 7-in-1			7315 kg
TURNING RADIUS	A1. Inner wheels not braked* Over Tires Over Bucket	8.4 m (27'7")		11.1 m (36'5")
	B1. Inner wheels braked* Over Tires Over Bucket * with 12.5x18-12 PR tires	7.2 m (23'8")		10.0 m (32'10")
CAPACITY	Fuel Tank	160 L	Transmission	15 L
	Engine Coolant	16 L	Rear Axle	17.5 L
	Engine Oil	9.1 L	Hydraulic Oil	90 L
OPTIONS	A/C Cabin / Canopy	Four Wheel Drive (Instead of 2WD)		7-in-1 Clam-Shovel
	Range of Trenching Buckets Extendable Dipper	Ditch Cleaning Bucket		1.2 cu m Loader Bucket

REFERENCE DIAGRAMS

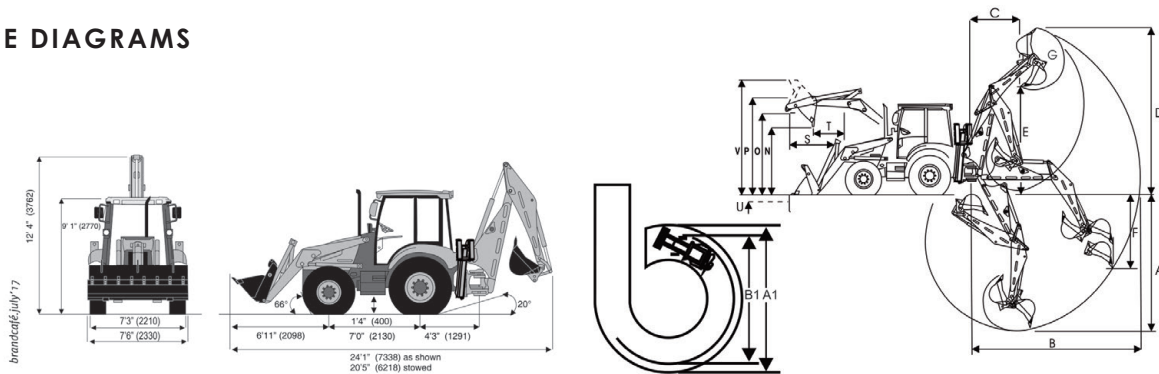

Effective Date: September, 2017. All dimensions, weights, and timings are variable within 1.5%. Company reserves the right to change specifications without prior notice. The illustrations do not necessarily show the standard version of the machine. Product specifications and prices are subject to change without notice or obligation. The photographs and/or drawings in this document are for illustrative purposes only. Refer to the appropriate Operator's Manual for instruction on the proper use of this equipment. Failure to follow the appropriate Operator's Manual when using our equipment or to otherwise act irresponsibly may result in serious injury or death. The only warranty applicable to our equipment is the standard written warranty applicable to the particular product and sale and we make no other warranty, express or implied.

Manitou Equipment India Pvt. Ltd.

Plot No. 22, Udyog Vihar, Greater Noida, P.O. Surajpur, Gautam Budh Nagar, U.P.-201306, INDIA
Tel.: +91-120-4194100 Fax: +91-120-2560541, Email: tepl.marketing@manitou-group.com Web: www.gehl.com

© 2017 Manitou Equipment India. Gehl. All rights reserved. A Manitou Group Brand. BL818_(09-2017)_IN

GEHL
gehl.com

Find us on
Facebook

GEHL COMPACT EQUIPMENT