

DESBROZADORAS FRONTALES FLAIL MOWERS

mods. DF 1300 • 1500 • 1750 • 2000 • 2300

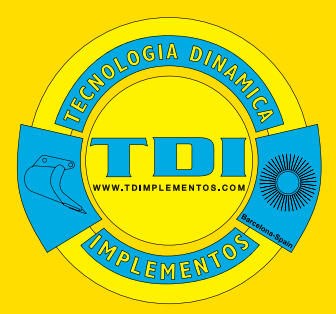

PowerAttachments®



Expertos en implementos
Attachments experts



APLICACIONES

Ideal para la limpieza y desbrozado de hierbas, arbustos y pequeños árboles en el mantenimiento y conservación de bosques, parques, jardines, parcelas...

CARACTERÍSTICAS TÉCNICAS

Fácil de adaptar a minicargadoras, midicargadoras, retrocargadoras, telescópicas, vehículos multiusos..., transmisión por reductor a correas, rulo nivelador regulable, protector antiproyecciones, dos versiones disponibles: con martillos acodados o con cuchillas, no requiere drenaje. A+B. Enganche desplazado (*) y tomas hidráulicas para la máquina portante.

APPLICATIONS

Specially suitable for grass cleaning and grinding, shrubs and small trees in the maintenance and conservation of forests, parks, gardens, plots ..

FEATURES

Easy adapt to skid steer loaders, midloaders, backhoe loaders, telehandlers, multipurpose vehicles ..., transmission by gearbox to straps, adjustable leveling roller, security cover, available in two versions: with hammers or blades, don't requires casedrain line. A+B. Attach shifted to the right (*) and hydraulic hoses for the carrier machine.

MODELO (referencia)	ANCHO (mm)	NÚMERO DE MARTILLOS	NÚMERO DE CUCHILLAS	CAUDAL RECOMENDADO (lpm)	CAPACIDAD (lts)	PESO (kg)
DF-1300	1280*	12	36	45 - 55	170 - 205	485
DF-1500	1480*	16	48	50 - 60	170 - 205	505
DF-1750	1730	16	48	65 - 75	170 - 205	530
DF-2000	1980	20	60	80 - 90	170 - 205	560
DF-2300	2280	20	60	95 - 105	170 - 205	600
MODEL (reference)	WIDTH (mm)	NUMBER OF HAMMERS	NUMBER OF BLADES	RECOMMENDED FLOW (lpm)	CAPACITY (lts)	WEIGHT (kg)

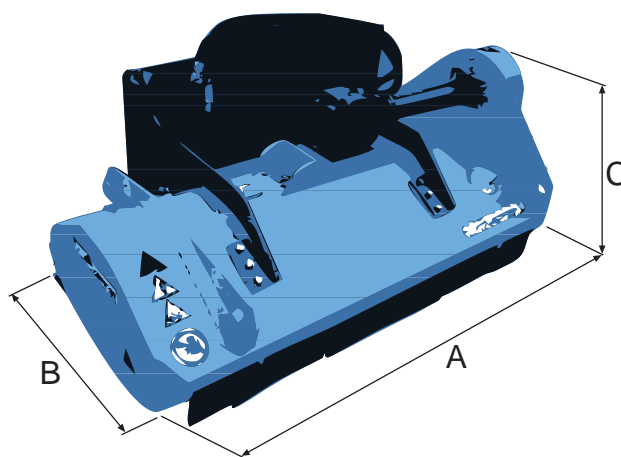

MODELOS DF / DF MODELS	1300	1500	1750	2000	2300
A Ancho total (mm) / Total width (mm)	1.420	1.620	1.870	2.120	2.420
B Largo total (mm) / Total lenght (mm)	1.000	1.000	1.000	1.000	1.000
C Alto total (mm) / Total height (mm)	430	430	430	430	430
• Ancho trabajo (mm) / Work width (mm)	1.280	1.480	1.730	1.980	2.280
• Peso (kg) / Weight (kg)	485	505	530	560	600