

Strength and efficiency

The hydraulic breaker is an equipment of the earth-moving and mining industry, whose components are subjected to high levels of stress, working mostly in difficult situations.

In order to make hydraulic breakers increasingly reliable and guarantee performance and power, Hammer Srl has introduced the SB and FX lines, obtained with in-depth R&D studies carried out in over 30 years of activity.

For the production of these ranges, the best high-alloy steels on the market are used and the best heat treatment techniques developed.

The research and studies carried out have allowed us to obtain important results in terms of the technological and mechanical characteristics of the steels.

At the same time, studies were carried out in collaboration with the main producers of hydraulic seals (Trelleborg, Freudenberg, Nok).

Over the years we have therefore improved the quality of the materials used and the types of the same, so as to adapt them to the right ratio between the variables speed, pressure,

temperature, obtaining thus greater durability.

With ref. to SB and FX series, Hammer Srl, thank to its experience, has chosen to design and build "nitrogen" breakers in order to obtain a high power distributed over a higher number of blows per minute, thus resisting high counterpressures up to 25 bar.

The breaker is also very compactly structured to reduce stress on the excavator arm and ensure greater durability of both the breaker itself and its components.

- The SB and FX hydraulic breakers can work on any type of excavator and on any single-acting hydraulic system; they are also suitable for hydraulic systems with high back pressure

- HAMMER Breakers are equipped with special polyurethane shock absorbers that absorb vibrations, thus protecting the arm of the excavator and also reduce noise emissions, according to the requirements of directive 2000/14 / EC

The HAMMER breakers of the SB series are suitable for carriers, mini excavators, mini-blades, backhoe loaders, demolition robots. etc...

The HAMMER breakers of the FX series are suitable for medium and large crawler and wheeled excavators, etc...

SB Series

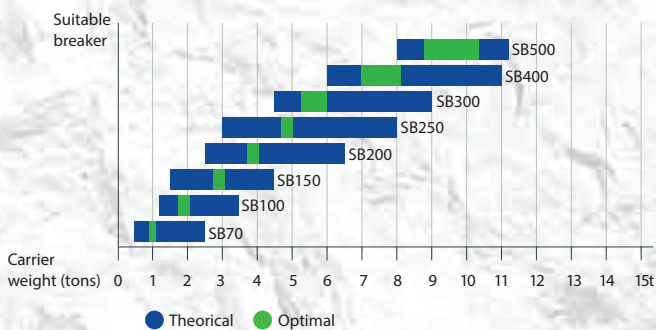

FX Series

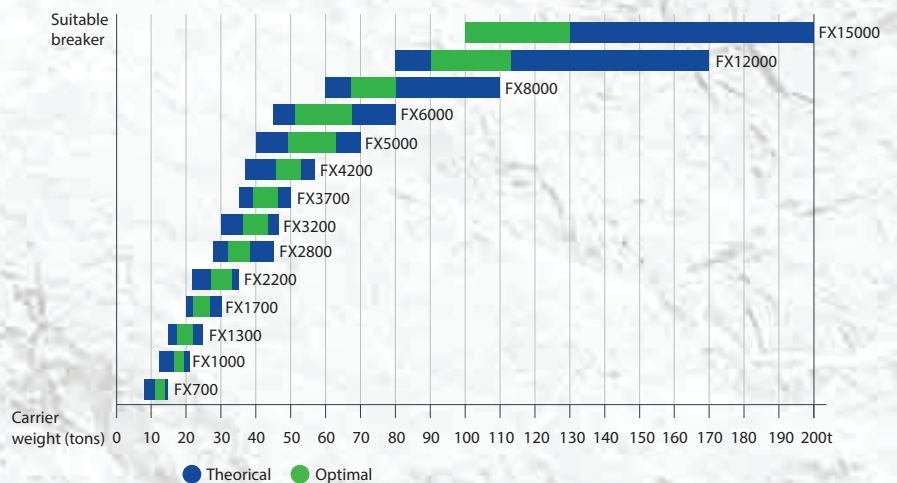

Application overview

Mining & quarrying



Preliminary works	<ul style="list-style-type: none"> › Overburden removal › Bench, road & ramp leveling › Roof, face & rib scaling
Secondary breaking	<ul style="list-style-type: none"> › Boulder reduction in rock pile › Removing blockages at crushing systems
Primary rock breaking	<ul style="list-style-type: none"> › Selective rock breaking › Blast-free mining

SB	FX (700-1700)	FX (2200-15000)
●	●	●
●	●	●
●	●	●

Demolition & renovation



Masonry structures	<ul style="list-style-type: none"> › Brickwork › Natural stone › Autoclaved aerated concrete
Concrete structures	<ul style="list-style-type: none"> › Lightweight concrete › Standard concrete
	<ul style="list-style-type: none"> › Heavyweight concrete
Composite steel & concrete structures	<ul style="list-style-type: none"> › Steel-reinforced concrete › Prestressed concrete › Fiber-reinforced concrete
Pavements	<ul style="list-style-type: none"> › Asphalt › Concrete › Composite surfaces

●	●	●
●	●	●
●	●	●
●	●	●
●	●	●

Construction



Earthworks	<ul style="list-style-type: none"> › Trenching › Pit building › Ground excavation
Tunneling	<ul style="list-style-type: none"> › Tunnel driving › Roof, face & rib scaling › Floor leveling
Dredging	<ul style="list-style-type: none"> › Canal deepening & extension › Dock deepening & extension
Gardening & Landscaping	<ul style="list-style-type: none"> › Fencing › Ground excavation › Rock breaking
Foundation works	<ul style="list-style-type: none"> › Ground leveling
Building construction	<ul style="list-style-type: none"> › Foundation pile driving

●	●	●
●	●	●
●	●	●
●	●	●
●	●	●
●	●	●

Metallurgical industry



Slag recycling	<ul style="list-style-type: none"> › Boulder reduction in slag heap › Removing blockages at crushing systems
Cleaning & debricking	<ul style="list-style-type: none"> › Ladles › Converter mouths › Kilns

●	●	●
●	●	●

● Optimal ● Suitable ● Unsuitable

Features and benefits

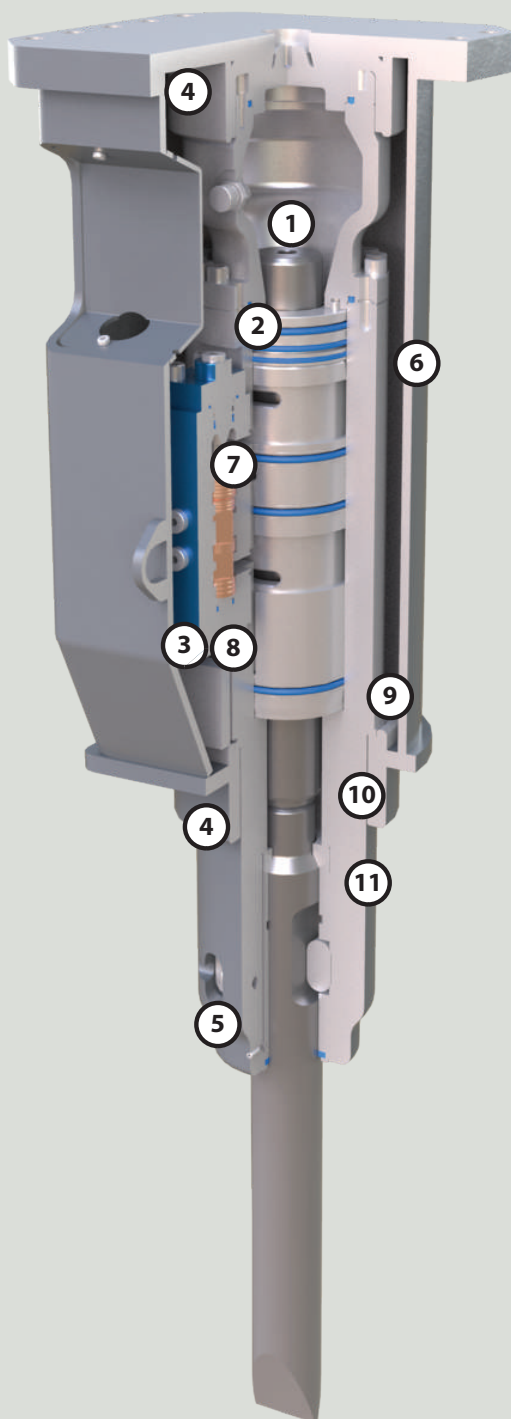

SB SERIES

- 1** More power and less vibration and maintenance
The SB breakers work with inertial nitrogen energy recovery, obtaining more power (more than 30%) and less vibration thanks to the nitrogen chamber which reduces maintenance costs, since it has no diaphragms inside it.
- 2** Long lasting of the nitrogen charge
In the past, energy recovery breakers required frequent nitrogen refills; with the new sealing system and the new compound developed by Freudenberg they are able to guarantee a gas tightness equal to 300% more than in the past.
- 3** Protected tubes
The tubes are completely protected through the casing and they're suitable for every type of excavation, especially in narrow spaces.
- 4** Silenced body
The particular construction, with a closed box casing as well as the insertion of sound-absorbing material, allowed to reach very low noise levels for a breaker.
- 5** Double retainer pin
The tool locking system with double retainer pin allows an adequate and uniform wear of the same and ensures longer maintenance intervals for the whole locking system.
- 6** Monobloc body without tie rods
The entire SB series benefits from the particular monobloc construction; this feature gives the structure a very high resistance to leverage, during work. The breaker is built in one only piece and it is without tie rods, thus obtaining more production and less maintenance for our customers.
- 7** Only two moving parts
- 8** For all types of installations (pressurization)
The SB series tolerates high back pressure values and has a wide calibration range of the required oil flow, in order to facilitate installation.
- 9** The piston moves in a single interchangeable cylinder liner, easy to replace in case of necessity, keeping intact the main body

- 10** Piston constructed with a special geometry such as to keep a constant energy of impact, as well as reducing breakages in conditions of criticality
- 11** Visibility and versatility
The breakers of the SB series, with their tapered shape, provide the operator with an excellent view during the work and allow to operate close to the walls, both in narrow section and with open front.

Principle of operation

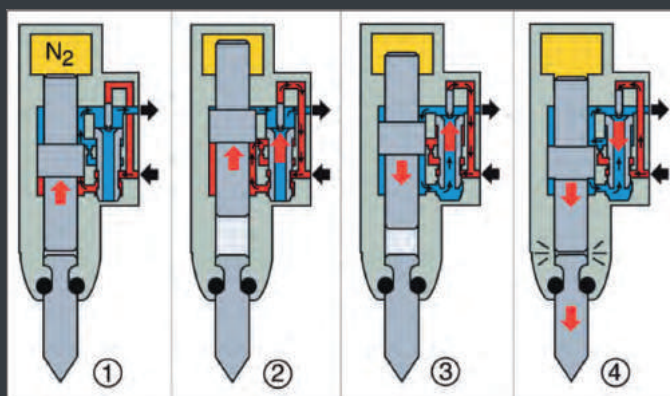

Tools • SB Series



Moil Point

Suitable for concrete, for medium-hard and not layered rocks.



Blunt Tool

Suitable for reinforced concrete and very compact rocks.



Pyramid Tool

Suitable for reinforced concrete and very compact rocks.



Chisel Tool

Suitable for medium-hard and layered rocks.



Wood Cutter Tool

Suitable for cutting all types of wood.



Pile Driver

Suitable for planting wooden or concrete poles.



Asphalt Cutter

Suitable for cutting asphalt



SB Series

Complete with:

- N.1 Plate for bracket
- N.2 Tools (chisel, blunt, moilpoint or pyramidal)

Optional:

- N.2 Hoses
- N. Special tools (wood cutter, pile driver, asphalt cutter)
- N.1 Nitrogen bottle 1.5 lt
- N.1 Automatic greaser lube



DATA SHEET



SB Series

Complete with:

- N.1 Plate for bracket
- N.2 Tools (chisel, blunt, moilpoint or pydamidal)

Optional:

- N.2 Hoses
- N. Special tools (wood cutter, pile driver, asphalt cutter)
- N.1 Nitrogen bottle 1.5 lt
- N.1 Automatic greaser lube



DATA SHEET



Model		SB 70	SB 100	SB 150	SB200	SB 250	SB 300	SB 400	SB 500
Peso excavatore Carrier weight Poids de l'engin porteur Trägergewicht Peso excavadora	t lb	0,5-2,5 1100/5500	1,2-3,5 2600/7700	1,5-4,5 3300/9900	2,5-6,5 5500/14300	3,0-8,0 6600/17600	4,5-9,0 9900/19800	6,0-11 13200/24200	8,0-11 17600/24200
Peso martello Weight Poids Gewicht Peso	kg lb	70 155	100 220	145 320	190 419	250 551	320 706	430 948	540 1191
Altezza con utensile standard Height with standard tool Hauteur avec outil standard Höhe inkl. Standardmeißel Altura con puntero estándar	mm inch	900 35	1000 39	1100 43	1200 47	1250 49	1550 61	1650 64	1700 66
Diametro dell'utensile Chisel diameter Diamètre de l'outil Meisseldurchmesser Diámetro del puntero	mm inch	40 1,5	45 1,7	48 1,8	55 2,1	65 2,5	75 2,9	80 3,1	90 3,5
Portata olio rich. Required oil supply Débit d'huile nécessaire Erforderliche Ölmenge Caudal del aceite	l/min gpm	13-20 3,4-5,3	15-30 4-8	18-40 4,7-10,5	25-55 6,6-14,5	30-60 7,9-15,8	50-70 13,2-18,5	75-90 19,8-23,7	85-110 22,5-29
Pressione dell'olio regolata al martello Oil pressure adjusted to the hammer Pression de l'huile vers le marteau Betriebsdruck Presión del aceite en el martillo	bar psi	100 1450	110 1595	110 1595	130 1885	140 2030	160 2320	150 2175	150 2175
Numero dei colpi / min. Blows per minute Coups par minute Schlagzahl / Min. Número de golpes/min.	/min /min	900-1100 900-1100	900-1100 900-1100	900-1100 900-1100	900-1100 900-1100	900-1100 900-1100	800-1000 800-1000	700-900 700-900	600-800 600-800
Energia del colpo Energy per blow Energie par coup Schlagzahl/ Energia del golpe	J J	280 280	400 400	580 580	750 750	950 950	1200 1200	1700 1700	2300 2300
Contropressione max Max. back pressure Contre-pression maxi Max. Gegendruck Contrapresión max.	bar psi	25 362	25 362	25 362	25 362	25 362	25 362	25 362	25 362
Diametro tubo entrata Inner diam. IN hose Diam. intérieur tuyau H.P. Innendurchm. Hammervorlauf Diám. interior manguera presión	inch inch	1/2" 1/2"	1/2" 1/2"	1/2" 1/2"	1/2" 1/2"	1/2" 1/2"	3/4" 3/4"	3/4" 3/4"	3/4" 3/4"
Diametro tubo uscita Inner diam. OUT hose Diam. intérieur tuyau B.P. Innendurchm. Hammerrücklauf Diám. interior manguera retorno	inch inch	1/2" 1/2"	1/2" 1/2"	1/2" 1/2"	1/2" 1/2"	1/2" 1/2"	3/4" 3/4"	3/4" 3/4"	3/4" 3/4"



*All illustrations and numerical data in this catalog are purely indicative and subject to change at our discretion and without notice. We therefore reserve the right to modify them with a view to improving and continuously developing our product.



*Tutte le illustrazioni e i dati numerici in questo catalogo sono puramente indicativi e suscettibili di modifica, a nostra discrezione e senza preavviso. Ci riserviamo pertanto il diritto di modificarli nell'ottica del miglioramento e sviluppo costante del nostro prodotto.



Valvola di Velocizzazione
Speed Valve
Eilgangventil
Speed Valve
Valvula de Velocidad
Скоростной клапан



Intensificatore di potenza BOOSTER
Intensifier of power Booster
Drueckverstaerker Booster
Intensificateur de puissance BOOSTER
Multiplicador de potencia Booster
Интенсификатор давления



Peso attrezzatura
Equipment weight
Eigengewicht
Poids de l'outil
Peso del implemento
Вес оборудования

Rotazione continua 360°
360° rotation
360° Kontinuierliche Rotation
Rotation continue 360°
Rotación continua a 360°
Непрерывное вращение на 360°



Peso escavatore
Excavator weight
Baggergewicht
Poids du porteur
Peso Escavadora
Вес экскаватора

Portata olio della rotazione
Rotation oil flow capacity
Oelfluss der Rotation
Débit hydraulique rotation
Caudal de aceite necesario para la rotación



Peso escavatore - posto benna
Excavator weight - stick mounting
Baggergewicht - Loeffelstiehlmontage
Poids du porteur - au but du
Peso escavadora al segundo brazo
Вес экскаватора (Рукоять)

Pressione di esercizio rotazione
Rotation Pressure
Oeldruck der Rotation
Pression hydraulique rotation
Presión necesaria para la rotación
Давление ротации



Peso escavatore - posto braccio
Excavator weight - boom mounting
Baggergewicht - Baggerarmmontage
Poids machibe - montage a la place du
balancier
Peso escavadora al balancin

Pressione di esercizio escavatore
Excavator working pressure
Oeldruck der Bagger
Pression hydraulique excavateur
Presión de la Escavadora
Давление откр./закр. челюстей



F3

Forza in punta
Tip force
Schliesskraft auf die Spitze
Force à la pointe
Fuerza en punta
Мощность на наконечнике

Portata olio escavatore
Excavator oil flow capacity
Oelfluss der Bagger
Débit hydraulique excavateur
Caudal aceite de la Escavadora
Поток откр./закр. челюстей



Lunghezza lama
Steel blade length
Messerlaenge
Longuer couteau
Anchura cuchilla
Длина ножей